

Go man®

serie **OPEN**
eleganza accessibile





Francesco Rodighiero

Designer

Designer, nasce nel 1977. Studia disegno industriale al Politecnico di Milano dove si laurea nel 2003. Dal 1998 partecipa all'organizzazione di diverse esibizioni d'arte e design. Recentemente, dopo alcuni anni spesi a Barcellona lavorando ad alcuni interni commerciali, è stato tutor presso la Domus Academy nel corso di Interaction Design. Nel 2006 ha vinto la borsa di studio per il Master di I livello in Bathroom Design presso il Polidesign di Milano.

Partecipa a numerose esposizioni collettive di design a Milano, Londra, Berlino e Los Angeles. Nel 2010 con il lavabo Flight ha ricevuto prestigiosi riconoscimenti quali: IF Product Design Award 2010, WT Award 2010 e Designpreis 2011. Nel 2011 diventa socio del Design For All Italia.

He is a designer and was born in 1977. He studied Industrial Design at the Polytechnic in Milan, where he graduated in 2003.

From 1998 on he has been involved in the organisation of different Art and Design exhibitions. Recently, after having spent some years in Barcelona working as an Interior designer for some companies, he was a tutor of Interaction Design at the Domus Academy. In 2006 he won a scholarship for a Masters degree in Bathroom Design at the Polidesign in Milan.

He has attended numerous design collection exhibitions in Milan, London, Berlin and Los Angeles. In 2010 he received many awards for his Flight washbasin such as: IF Product Design Award 2010, WT Award 2010 and Designpreis 2011. In 2011 he became a partner of Design For All Italia.

Rossano Zambelli

Research & Development

Nel 2005 l'azienda incorpora il tecnico Rossano Zambelli che, mentre crea il reparto Ricerca & Sviluppo, fa conseguire senza troppe difficoltà e tra le prime aziende Italiane del settore, la certificazione ISO 9001 con gli enti TÜV, AENOR, IQNET, certificazioni che comprovavano una politica aziendale intesa al mantenimento e miglioramento della qualità mediante procedure formalizzate.

Forte di un'esperienza ventennale collabora a tutti i progetti Open e alla registrazione di 4 brevetti internazionali. Nel 2010 e 2011 coopera attivamente con l'azienda Goman e lo studio Rodighiero associati per il progetto Flight, con il quale riceveranno 3 prestigiosi award all'innovazione e al design: If product Design - Designpreis Deutschland e Wt award.

In 2005 the company incorporated the technician Rossano Zambelli that, while creating the Research and Development department, was able to attain with ease the ISO 9001 certification. It was among the first Italian companies to gain this certification which gave further evidence of a company policy intent on maintaining and improving quality by means of set procedures. With the strong backing of twenty years experience he is involved in all the Open projects and in the registration of 4 international patents. In 2010 and 2011 he played an active part working with the Goman company and Rodighiero Associates design studio for the Flight project, for which he received 3 prestigious awards for innovation and design: If product Design - Designpreis Deutschland and the Wt award.

C'è un raggio di luce per chi è in ombra.

There's a light for those in the shadow.





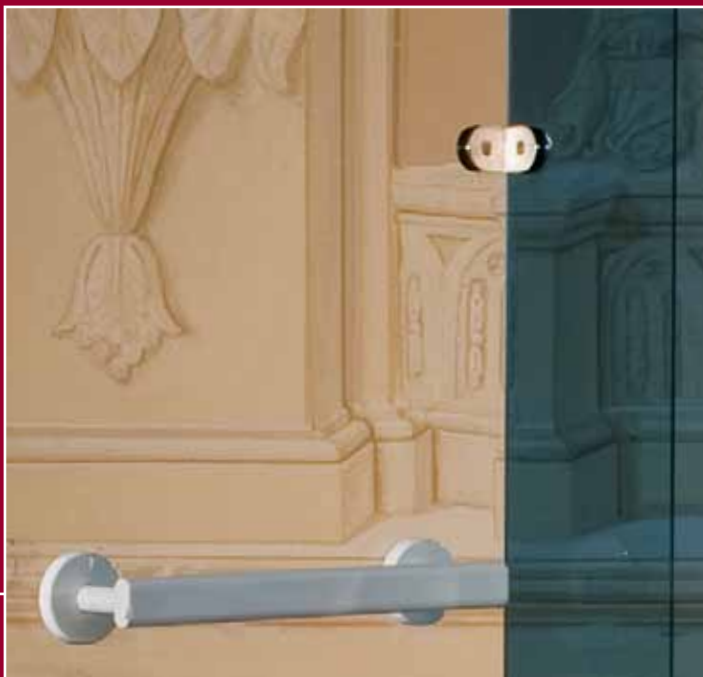

Eleganza. Da anni anziani e diversamente abili hanno perso il diritto alla normalità, nella costrizione di oggetti palesemente 'diversi' dagli altri.

Oggi, il rispetto delle normative e il diritto a un bagno sicuro non sono più lo specchio di un ambiente dall'aspetto tecnico e sgradevole.

Con la serie OPEN, Goman® apre nuovi scenari di recupero della normalità e della dignità che la sicurezza e la legge non possono oscurare. Una nuova luce per ambienti che devono essere aperti a tutti e a tutte le situazioni nel rispondere, con stile, alla necessità di appropriati ausili tecnici.

Elegance. Since many years old people and disable people have lost their right to feel "normal", being forced to the use of objects that are visibly "different". Today, respect for the norms and the right of using safe restrooms are not the mirror of a purely technical and unpleasant environment.

With the OPEN series, Goman® uncloses new scenarios for the recovery of the normality and the dignity that law and security cannot shadow.

A fresh light on spaces that must be open to everyone and every situation in answering with style to the need for appropriate technical aids.







serie **OPEN**
eleganza accessibile

Accessibilità. La serie OPEN di Goman® abbattere le barriere estetiche normalmente presenti nelle residenze per anziani, nei locali pubblici quali bar, ristoranti, discoteche e ovunque la legge imponga l'uso di ausili e accessori di sicurezza. Anche nelle abitazioni, la serie OPEN di Goman® è garanzia di eleganza e accessibilità per tutti i componenti della famiglia.

Accessibility. The OPEN series breaks down the aesthetic barriers usually present in retirement homes, public sites such as bar, restaurants, clubs and anywhere the law prescribes the use of security complements and accessories. In private houses, the OPEN Goman® series is a grant of elegance and accessibility for all family members.





serie **OPEN**

Lavabo OPEN

Vaso alto OPEN

Bidet alto OPEN

Vaso sospeso OPEN

Bidet sospeso OPEN

Maniglia OPEN cm. 40 - 60 - 90

Maniglia OPEN 45°

Maniglia OPEN 40x70 - 90°

Angolare OPEN 70x70

Barra ribaltabile OPEN cm. 70

Specchio reclinabile

Portarotolo

Appendino

Wash -basins

Ceramic WC

Ceramic bidet

Suspended WC

Suspended bidet

Handle cm. 40 - 60 - 90

Handle 45°

Handle 40x70 - 90°

Corner handle 70x70

Folding bar cm. 70

Adjustable tilting mirror

Paper holder

Hook



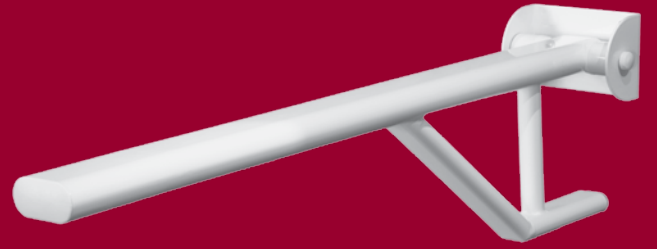

Go man®



serie **OPEN**
eleganza accessibile







Lavabo OPEN

Lavabo ergonomico OPEN, bordo anteriore concavo, con appoggiagomiti per facile utilizzo. Predisposto per installazione con tasselli di fissaggio, mensole e meccanismi pneumatici.

OPEN ergonomic wash-basin, hollow front hedge, with elbowrests for easier use. Preset installation aids with fixing holes, shelves and pneumatic mechanics.

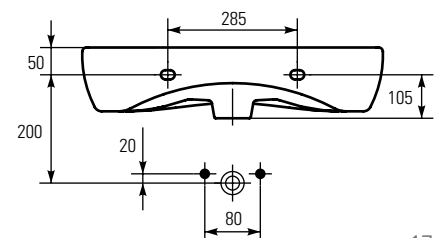
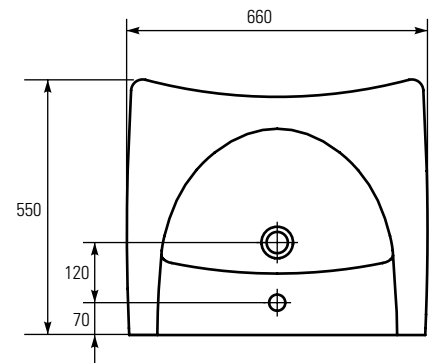
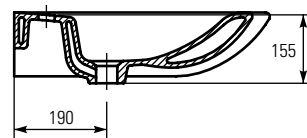





Miss Barra OPEN ribaltabile

design by
Rossano Zambelli

Leggera, snella, essenziale ma con struttura robusta, la barra Miss ha superato test di portata per oltre 300 kg. Ergonomica per comodo appoggio avambraccio e facile presa di mano, disponibile in qualsiasi colore delle tinte RAL. Realizzata in acciaio con trattamento anticorrosione, tubo ovale 60x30 rivestito con materiale antiusura antibatterico. Piastra in acciaio inox AISI 430. A richiesta accessorio portarotolo integrabile.

Light, slim, essential but with a strong structure, the MISS bar passed the weight test at over 300 Kg. Ergonomics for a comfortable support of the arm and an easy hand grip, the bar is available in several RAL colours. The bar is made by an oval tube 60x30, in steel with anticorrosion treatment, coated with antibacterial material. The plate is in stainless steel Inox AISI 430. Paper holder available on request.

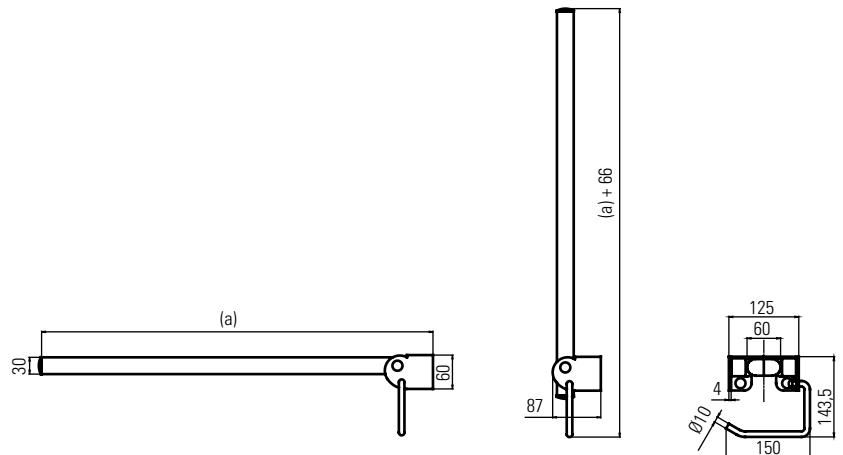



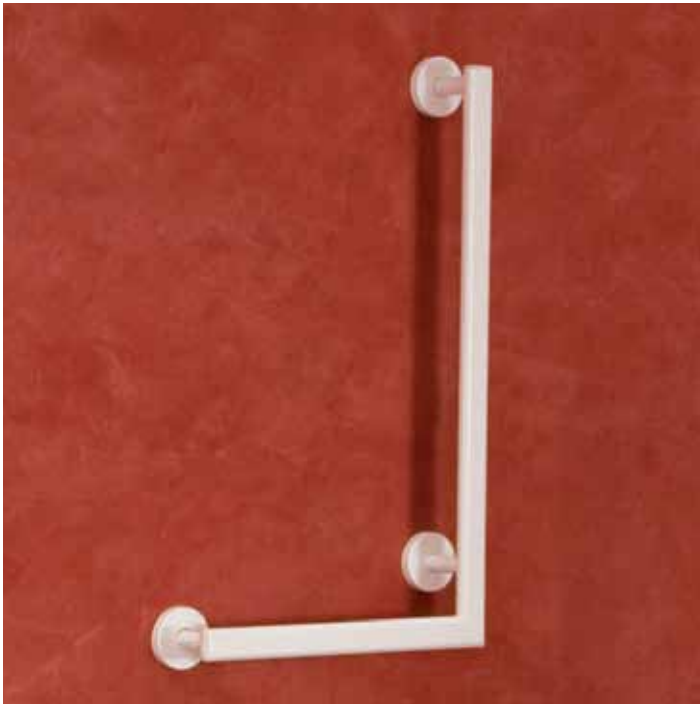

Maniglie OPEN

Una serie di forme e misure a completamento della gamma, realizzate con tubo acciaio ovale, trattamento anticorrosione, rivestite con materiale antiusura antisetico, capacità di carico 150kg.

Accessori utilizzabili da qualunque persona, eleganti, resistenti, ergonomici per allestire con sicurezza e stile la sala da bagno.

A series of shapes and sizes to complement the range, made in oval steel pipes with anti-corrosion treatment, covered with a durable antiseptic material and with a weight capacity of 150 kilos.

The accessories can be used by everyone and are elegant, strong and ergonomic. They fit into any bathroom respecting style and safety. Ideal for people with slight mobility problems and for those advanced in age.







Vaso OPEN

In ceramica con apertura frontale per funzione bidet, scarico unificato parete/pavimento, curva tecnica inclusa.

Ceramic with front opening for bidet function, unified wall/floor flushing, technical curve included.

Sedile OPEN

Coperchio con sedile aperto in termoidurente.

Seats cover WC with open seat in thermosetting resin.

Sedile OPEN PLUS

design by
Francesco Rodighiero

Sedile aperto con coperchio sagomato per occultazione foro in Duroplast, cerniere con o senza meccanismo "soft close". Brevetti BS2008U000002 e BS2008O000003.

Open seat in Duroplast with preformed cover for front opening hiding, hinges with "soft close" mechanics. Patent BS2008U000002 and BS2008O000003.

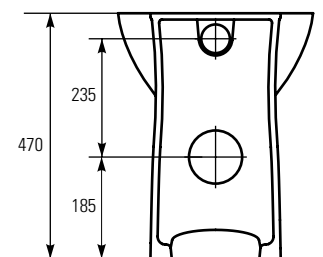
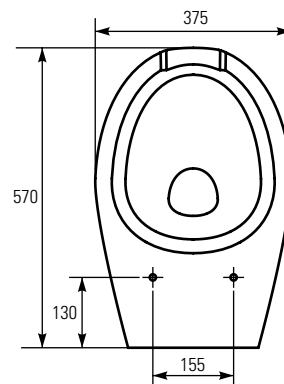
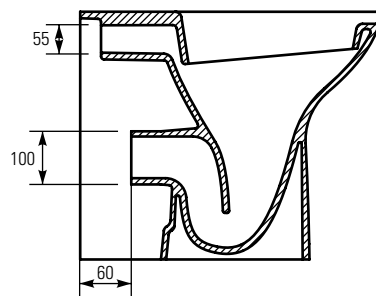
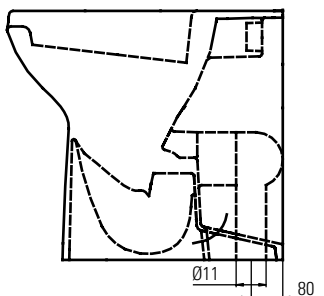





**Vaso alto
OPEN**

Vaso alto cm 47 in ceramica. Ideale per essere utilizzato da persone con difficoltà motorie e terza età.

Cm 47 hight ceramic wc. Ideal for people with mobility problems and for those advanced in age.

**Bidet alto
OPEN**

Bidet alto in ceramica. Ideale per essere utilizzato da persone con difficoltà motorie e terza età.

Cm 47 hight ceramic bidet. Ideal for people with mobility problems and for those advanced in age.

**Sedile vaso alto
OPEN**

Sedile chiuso e coperchio in MDF/poliestere.

Seat for hight wc: MDF close seat and cover.

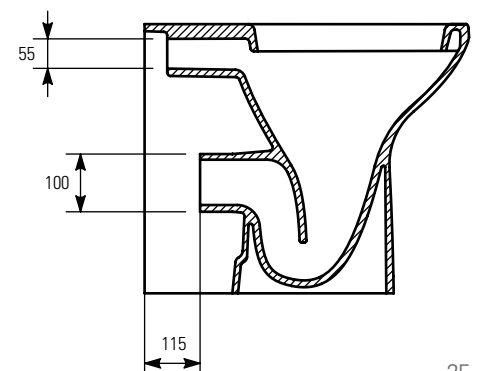
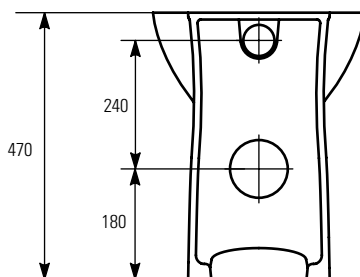
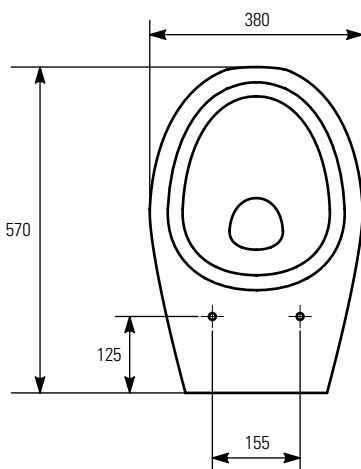





Vaso sospeso OPEN 75

Vaso sospeso cm 75 in ceramica. Ideale per essere utilizzato da persone con difficoltà motorie e terza età.

Cm 75 suspended ceramic wc. Ideal for people with mobility problems and for those advanced in age.

Vaso sospeso OPEN 54

Vaso sospeso cm 54 in ceramica con apertura frontale per funzione bidet. Ideale per essere utilizzato da persone con difficoltà motorie e terza età.

Cm 54 suspended ceramic wc with front opening for bidet function. Ideal for people with mobility problems and for those advanced in age.

Bidet sospeso OPEN

Bidet sospeso in ceramica.

Suspended ceramic bidet.

Sedile OPEN PLUS

design by
Francesco Rodighiero

Sedile aperto in termoplastico, con coperchio sagomato per occultazione foro in Duroplast, cerniere con o senza meccanismo "soft close".

Brevetti BS2008U000002 e BS2008O000003.

Open seat in Duroplast with preformed cover for front opening hiding, hinges with "soft close" mechanics. Patent BS2008U000002 and BS2008O000003.

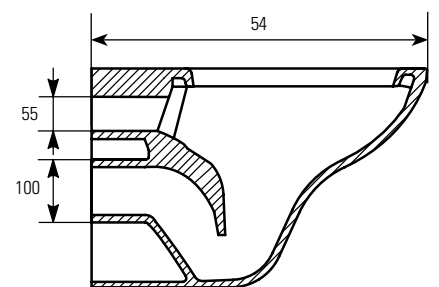
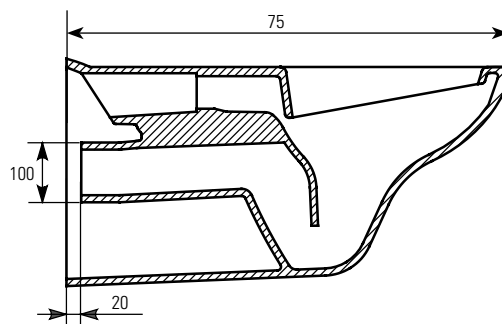
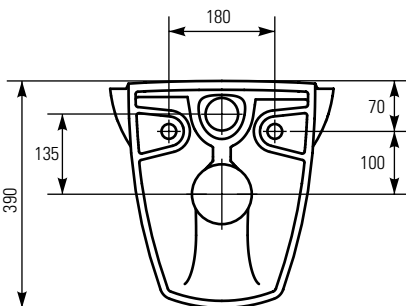



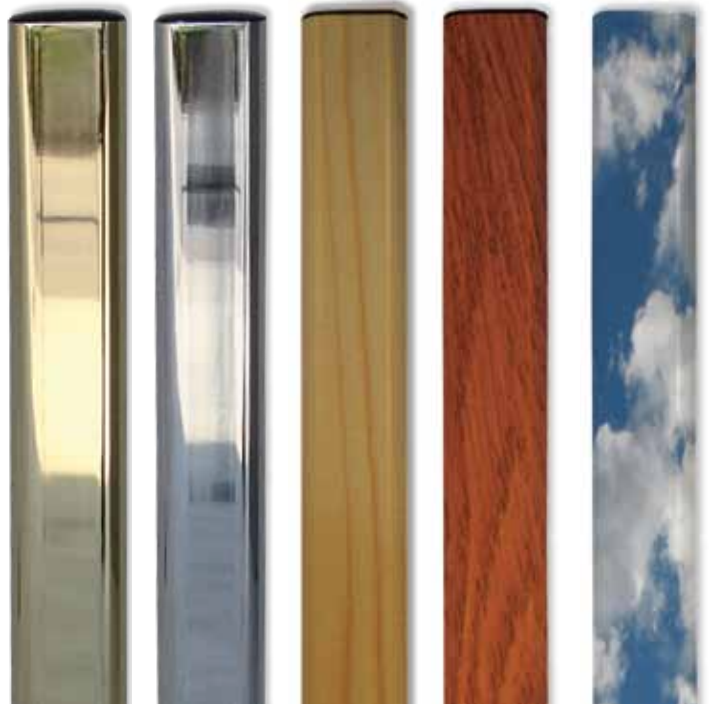

Serie Art collection

Un bagno accessibile si giudica anche dall'estetica. E allora perché non dare quel tocco in più d'eleganza e ricercatezza nel modo più semplice ed economico che ci sia? La serie Open è la prima e unica gamma di accessori per disabili che si integra e confonde perfettamente con le pareti.

Colore, semplicità, design, ergonomia e cinque innovative finiture: cromo, ottone, rovere chiaro, noce scuro, nuvole e tutta la gamma delle tinte RAL, per intonarsi ad ogni stile con sicurezza.

(N.B.- Solo la parte in bianco è disponibile nella finitura richiesta)

An easily accessible bath is judged as well by its nice looking; so, why don't try to give it an additional touch of elegance and refinement style in the most simple and economical possible way? Serie Open of Goman is the first and unique safety bars, which, due to its simplicity and convenience, can be automatically integrated in any environment. Colour, simplicity, ergonomics, and five innovative finishes: chrome, brass, light oak, dark walnut, cloudy and all RAL colours so as to tone in perfectly with any style.

(N.B. Only the parts in white are available in the choice of finishes)







Concept bar
design by
Francesco Rodighiero
Goman R&D

Presentata nei saloni espositivi di Milano, Barcellona e Francoforte ha consentito all'azienda di apprezzarne la validità mediante le reazioni del pubblico e della stampa specializzata.

La barra elettrica a scomparsa Open, è un tipo di barra ribaltabile per bagni disabili, destinata a definire un nuovo concetto di utilizzo, che non tiene conto dei vincoli imposti dagli standard produttivi e risponde a esigenze di sicurezza, ergonomia, mimesi, movimento non manuale e tipo d'impiego.

Questo primo esemplare, brevettato, è stato precursore di nuovi modelli anche di terze parti; ha mostrato che si possono ottenere innovative soluzioni di design for all e di tecnologie avanzate che potranno essere adottate nelle future produzioni. Studiata affinché si integrasse come gradevole accessorio in qualsiasi ambiente bagno, ha ispirato la realizzazione di tutta la Serie Open. Pur con le notevoli differenze dettate da esigenze produttive e di mercato, nella "miss barra open" si possono facilmente individuare le stesse impostazioni tecniche e stilistiche della barra elettrica a scomparsa.

The reaction of the public and press at its presentation in the exhibition rooms at Milan, Barcelona and Frankfurt has allowed us to confirm the validity of this product. The Open foldaway electric bar is a retractable bar for bathrooms for the disabled, defining a new concept of use that is not limited by the restrictions imposed by production standards.

It meets the requirements of safety, ergonomics, mimesis, non-manual movement and type of use. This first, patented model was the precursor of new ones, even those of competitors. It has shown that one can find innovative solutions of design for all and advanced technology that will be able to be adopted in the future. It has been designed so that it can be integrated as an attractive accessory into any bathroom; it has inspired all of the Open Series. Even with the notable differences dictated by production and market requirements, in the "miss barra open" can be clearly found the same technical and design features that are in the Open foldaway electric bar.



GOMAN S.r.l.
Via Maestri del lavoro, 8
Castiglione delle Stiviere
46043 - Mantova - **Italy**

Tel. +39.0376.671780
Fax +39.0376.671286

Per la gamma completa dei prodotti Goman
richiedere Il catalogo generale a **info@goman.it**

www.goman.it